

Harmonic Operator and Track Options

Columbia Elevator manufactures a time tested line of robust operator equipment with track and hanger options.

Columbia Harmonic Operator and track equipment is extremely well constructed using a design that has been tested with over 40 years of installations. In addition, Columbia's Harmonic Operator track is available for both the car side and entrance side.

Modernizations are simplified as this equipment is compatible with thousands of MAC® installations across North America. Available in a wide range of sizes, Columbia Harmonic Operator equipment is also well suited for new installations.

All of Columbia Operator and track equipment, including our closed loop operator, is manufactured in our facility by associates with years of experience

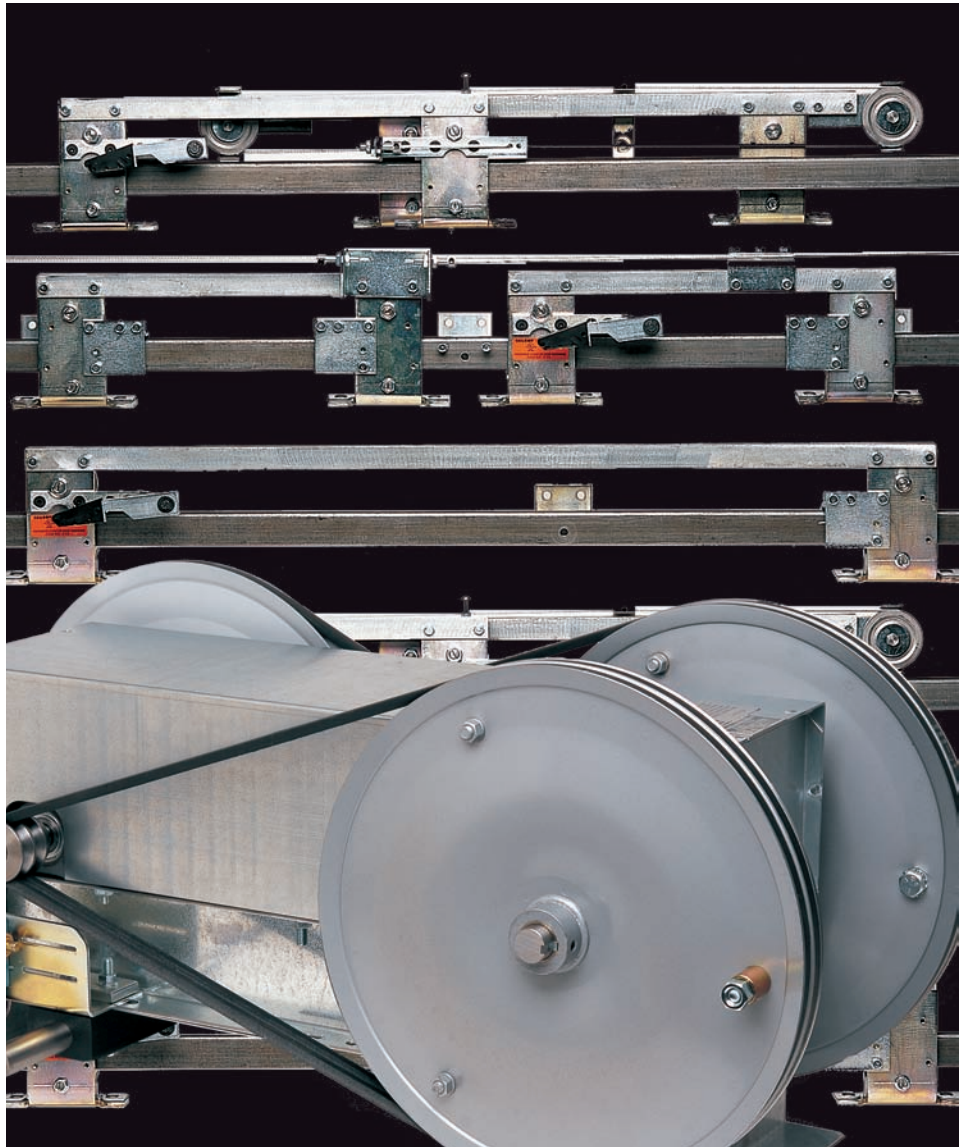

COLUMBIA
ELEVATOR

CABS ENTRANCES DOOR SYSTEMS

Harmonic Operator Options

888-858-1558
 www.columbiaelevator.com
 info@columbia-elevator.com

Standard Operator Packages

Standard Range Operator
 Split Link
 Long Lever Standard
 Crank Arm Adjustable
 DOOR DRIVE BLOCK

High Performance Operator Packages

High Performance Operator
 Split Link
 Long Lever Standard
 Crank Arm Adjustable
 DOOR DRIVE BLOCK

Closed Loop Operator Packages

Closed Loop Operator
 Split Link
 Long Lever Standard
 Crank Arm Adjustable
 DOOR DRIVE BLOCK

Auxiliary Shaft Operator Packages

High Perf. Aux. Shaft Operator
 Split Link
 Long Lever Standard
 Crank Arm Adjustable
 DOOR DRIVE BLOCK

Feature	S.Slide	Ctr.Opng.	2Spd.	2Spd/CO	Speed	Max Door Wt.
Standard Range	X	X	X		2.0-2.5 ft/sec	470#
High Performance / Closed Loop	X	X	X	X	2.5-3.0 ft/sec	500#
High Performance Auxiliary Shaft	X	X	X	X	2.0-2.5 ft/sec	525#

Feature	Standard Range	High Performance	High Performance Auxiliary
Permanent magnet D.C. motor	X	X	X
Integral solid state control	X	X	X
Ball bearing construction	X	X	X
Quiet V-belt drive	X	X	X
Full top cover (provides protection from potentially damaging elements)	X	X	X
Full bottom cover (isolates power supply)	X	X	X
Welded frame	X	X	X
Dual output power supply		X	X
Dual drive belts (reduces belt slippage due To increased torque)		X	X
Auxiliary reduction shaft (increases Mechanical advantage)			X

Harmonic Track Options

888-858-1558
 www.columbiaelevator.com
 info@columbia-elevator.com

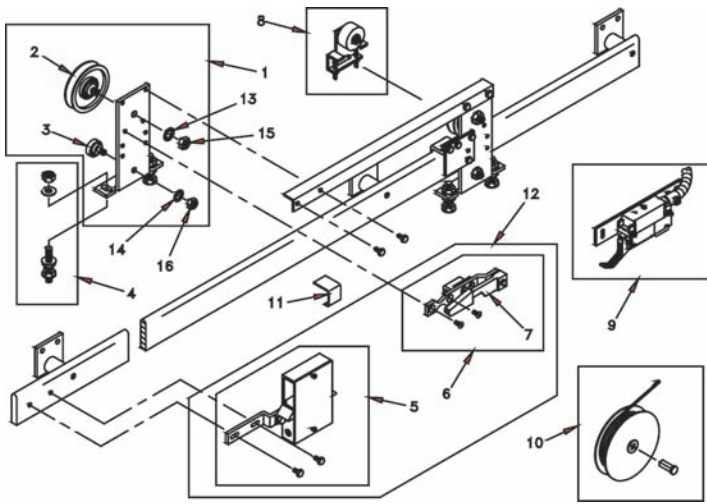

ES-1 SINGLE SPEED, SIDE-OPENING

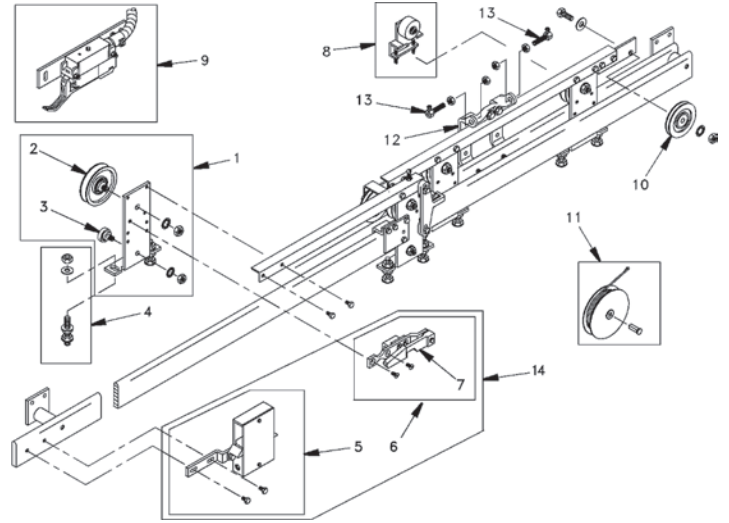

ES-1 TWO SPEED, SIDE-OPENING

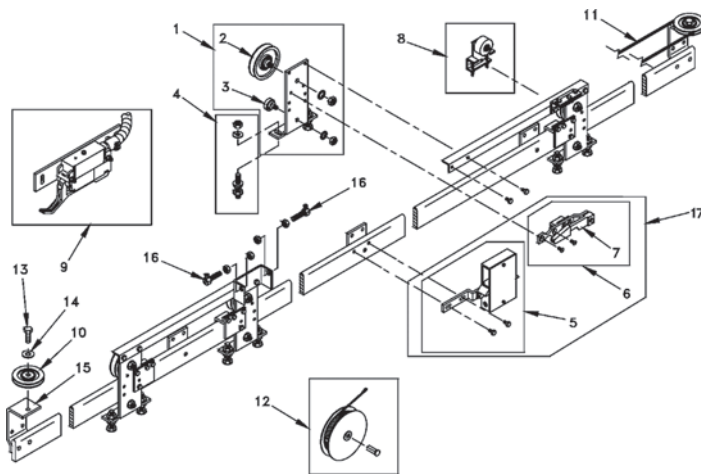

ES-1 CENTER OPENING

ES-1 Features

ES-1 Hangers are a dimensionally versatile hanger product line. (Also known as the "traditional hanger".)

Due to their versatility they are used on new construction, as well as modernization and service repair where building constraints require a custom designed hanger specifically for that application.

These building limitations can be narrow hoist ways, unusual opening widths door applications, or low pocket heights.

We have a design staff ready to work with general contractors, architects and elevator contractors to meet their needs of their specific application.

There are two configurations for the ES-1 Hanger $\frac{1}{2} \times 1\frac{1}{2}$ in.: Standard Duty track (hatch only), and $\frac{1}{2} \times 2\frac{1}{2}$ in. Heavy Duty track (car and hatch).

Double hanger pendants are attached by a pendant angle. It has non-eccentric polyurethane rollers that ride on the door track. It also has two configurations $2\frac{1}{2}$ in. running diameter for $1\frac{1}{2}$ in. track, and $3\frac{1}{4}$ in. running diameter for $2\frac{1}{2}$ in. track.

Eccentric upthrust rollers are positioned under the track to prevent the doors from being accidentally forced off the door track. It is also used for adjustment. The hangers are secured to the door with adjustable pendant bolts. The cable sheaves secure the $\frac{1}{8}$ in. flexible cabling. The track mounting brackets are used to mount the hanger to the header. The pendant angle is to support the pendants.

Hatch Hanger Packages

- Hatch Hanger
- Interlock
- Reel Closer
- Unlocking Arm
- Hatch Hardware

Car Hanger Packages

- Car Hanger
- Gate Switch
- Standard Clutch
- Car Hardware

Harmonic Parts Options

888-858-1558
 www.columbiaelevator.com
 info@columbia-elevator.com

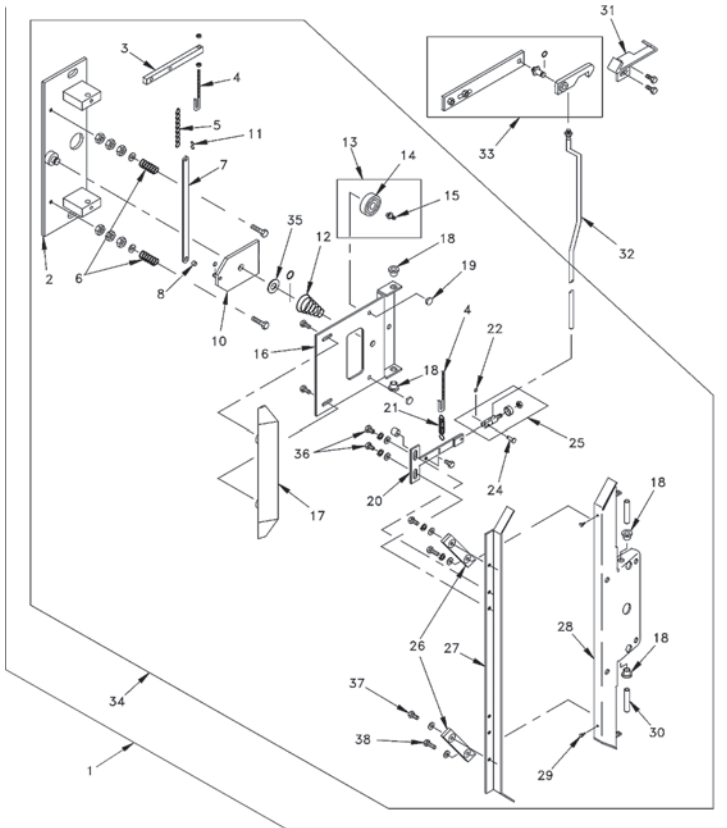

**Car Side
 Clutches: restrictive - 1 3/4 inch
 sill application**

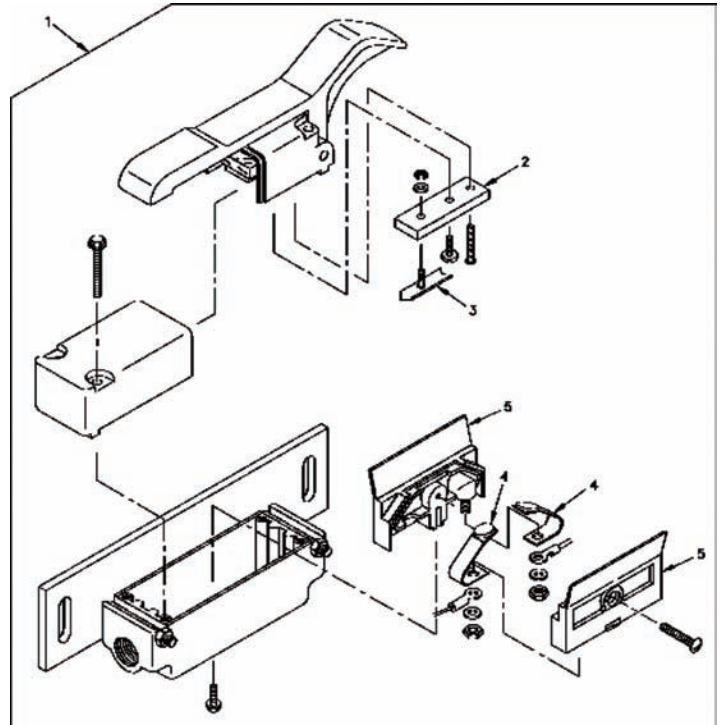

**Car Side
 Car Gate Switch**

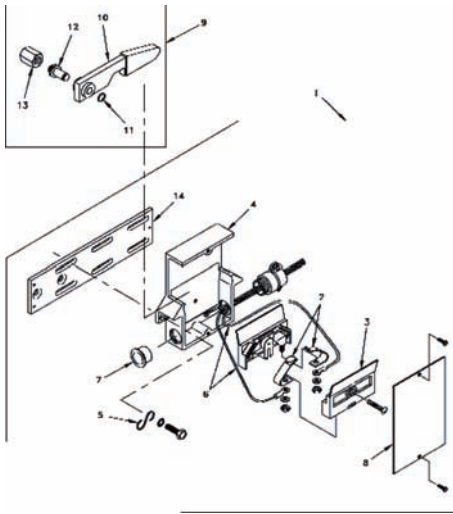

**Hatch Side
 Door interlocks: with
 1 3/4 inch sill**

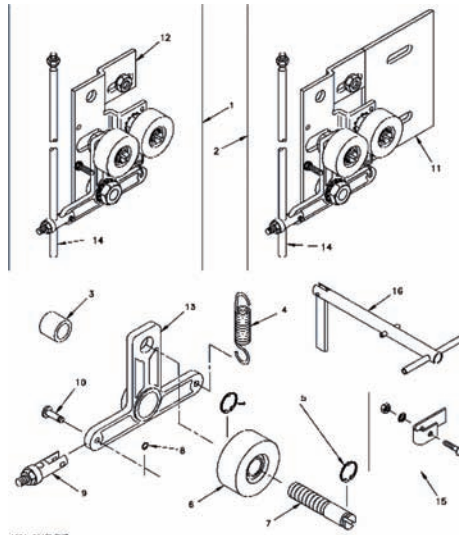

**Hatch Side
 Door drives:
 horizontal**

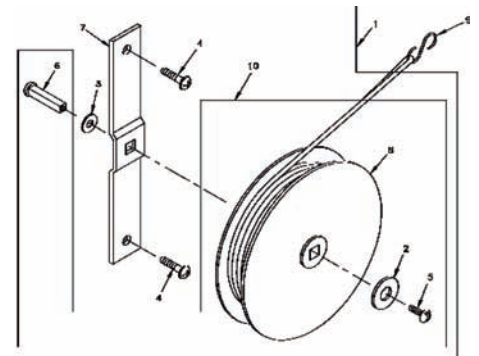

**Hatch Side
 Reel closers**